

BREATHING AIR SETS (PART NO. BREATHE)

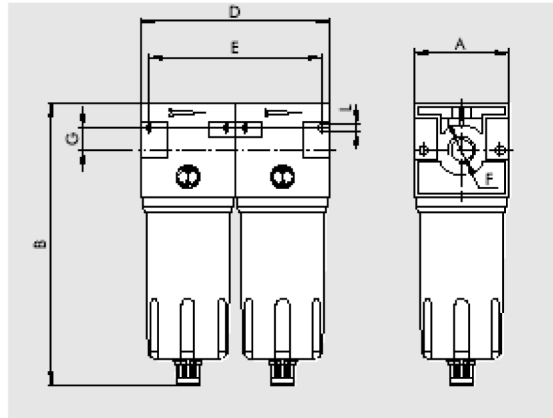

DIMENSIONS	
A	60MM
B	180MM
D	135MM
E	121MM
G	14MM
L	4MM HOLE

BREATHE provides high quality, clean air, essential for paint spraying and breathing air applications. Designed for self-contained operations, it will filter compressed air directly from most types of compressor and ring main systems.

**NOTE: THIS UNIT WILL NOT REMOVE
CARBON MONOXIDE (CO) & CARBON DIOXIDE (CO₂)**

BREATHE will supply sufficient breathable air for up to two men on constant demand flow and will provide breathing quality air to a higher standard than specified in BS4275: 1974

TECHNICAL SPECIFICATIONS

Element Grade	XA and AC
Port Size	1/2" BSP
Particle Removal	0.01 Microns
Max. Oil Carryover @ 20°C	0.005 mg/cu m
Max. Recommended Temperature	25°C
Pressure Loss Clean and Dry	150 mbar
Pressure Loss Saturated	350 mbar
Pressure Loss Change Element	400 mbar
Maximum Working Pressure	16 bar