

Fine Finish Texture Kit

310617E

Model 287227, Series A

Parts List

Ref.	Part	Description	Qty.
1	15B189	ADAPTER, nozzle	1
2	188354	NUT, retaining	1
3		DISK	
A	235579	1/8 in. (3.2 mm)	1
B	235580	1/4 in. (6.4 mm)	1
C	248311	5/16 in. (8.0 mm)	1
D	235581	3/8 in. (9.5 mm)	1

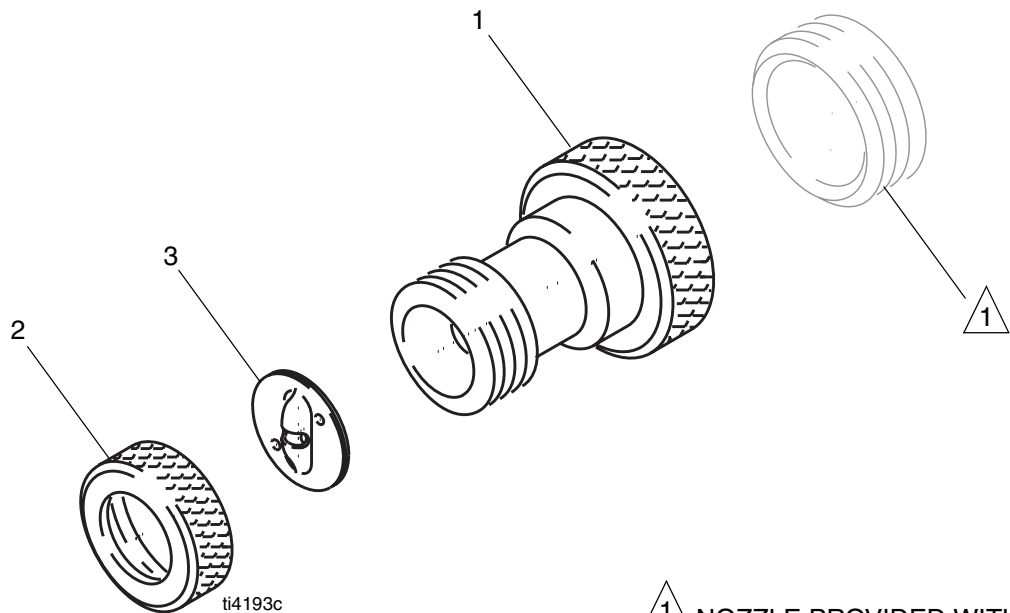

 NOZZLE PROVIDED WITH GUN

PROVEN QUALITY. LEADING TECHNOLOGY.

Installation

- 1 Remove retaining nut (2) from nozzle adapter (1).
- 2 Install disk (3) in retaining nut.
- 3 Install retaining nut and disk on nozzle adapter.
- 4 Install selected nozzle on gun.
- 5 Install retaining nut, disk, and nozzle adapter on gun.

Spray Techniques

The fine finish texture discs pre-atomize the texture material to give a finer finish for simulated acoustics and droplets of more consistent size and shape for splatter type finishes.

Spray Tip Selection Chart

Application	Fine Finish Disc	Nozzle (mm)	Air Volume
Simulated Acoustic - Fine - Medium - Coarse	B	4	High
	C	6	High
	D	8 - 10	High
Fog	A	3 - 4	High
Orange Peel	A or B	3 - 8	Medium to High
Splatter Coat	B or C	6 - 10	Low to Medium
Knock Down	D	8 - 12	Low

Graco Phone Numbers

To place an order, contact your Graco distributor or call this number to identify the distributor closest to you:
1-800-690-2894 Toll Free.

*All written and visual data contained in this document reflects the latest product information available at the time of publication.
Graco reserves the right to make changes at any time without notice.*

Graco Headquarters: Minneapolis
International Offices: Belgium, Korea, China, Japan
GRACO INC. P.O. BOX 1441 MINNEAPOLIS, MN 55440-1441
www.graco.com
Written in USA 310617E
5/2008